

THE ICONIC FORD FALCON XB GT

SCALE
1:8



Left Door Details

Published weekly
UK: £10.99 AUS: \$21.99



POST-APOCALYPTIC EDITION

THE ICONIC FORD FALCON XB GT

ISSUE 100

ASSEMBLY GUIDE

3

Parts are fitted around the left door opening and the door is fixed in place on the car body.

YOUR MODEL

You will be building a 1:8 scale replica of a customised 1973 Ford Falcon XB GT. Features include a lift-up bonnet that reveals a detailed engine, opening doors, wind-down windows and an 'active' steering wheel. A remote-control fob illuminates the main lights, brake lights and indicators.

Scale: 1:8
Length: 62cm
Width: 25cm
Height: 19cm
Weight: 7+kg



Ford Motor Company
trademarks and trade dress
used under licence to GRE
for Groupe ELIGOR

Official
Licensed Product

CUSTOMER SERVICE, SUBSCRIPTIONS & BACK ORDERS

Please visit hachettepartworks.com/contact to get in touch.

Published by Hachette Partworks Ltd
4th Floor, Jordan House, 47 Brunswick Place,
London, N1 6EB
www.hachettepartworks.com



© 2026 Hachette Partworks Ltd
© 2026 Ford Motor Company
Distributed in the UK and Republic of Ireland by Marketforce.
Printed in the United Kingdom
ISSN 2976-5811

Complete in 130 issues.

ALL RIGHTS RESERVED

Items may vary from those shown.

All parts belong to a kit. Collectors' item for adults. Not suitable for children under 14. Some parts may have sharp edges, please handle them with care.

The installation of electronic parts must always be carried out by an adult. When replacing batteries, use the same type of batteries. Please ensure that the battery compartment is securely fastened before you use the model again. Used batteries should be recycled. Please make sure to check with your local council how batteries should be disposed of in your area. Batteries can present a choking danger to small children and may cause serious harm if ingested. Do not leave them lying around and keep any spare batteries locked away at all times.

The editor's policy is to use papers that are natural, renewable and recyclable products and made from wood grown in sustainable forests. The logging and manufacturing processes are expected to conform to the environmental regulations of the country of origin.

In the event of a significant increase in production and transport costs, the publisher reserves the right to modify its selling prices.

MANAGING DIRECTOR – Isabelle Couderc
EDITORIAL DIRECTOR – Helen Nally
MARKETING DIRECTOR – Elise Windmill
PRODUCTION DIRECTOR – Sema Sant Anna
MANAGING EDITOR – Sarah Gale
PROJECT EDITOR – Gary Webb
DISTRIBUTION MANAGER – Paul Smith
PRODUCT MANAGER – Rhys Myrner



For our
environmental
policy in full
please scan the
QR code here



NOT SUITABLE FOR CHILDREN
UNDER THE AGE OF 14.
This product is not a toy and is
not intended for use in play.

Editorial and design: Windmill Books Ltd

Picture credits:

Front cover: Jess Esposito and David Burton, main;
Richard Bryden, bl; Shutterstock, Steven Giles, background

Step-by-step photography: Richard Bryden

Model photography: Jess Esposito and David Burton

Windmill Books has made every attempt to contact the copyright holder; if you have any information please contact Sophie Mortimer: smortimer@windmillbooks.co.uk



Stage 100: Left Door

Parts are fitted around the left door opening and the left door is fixed in place.

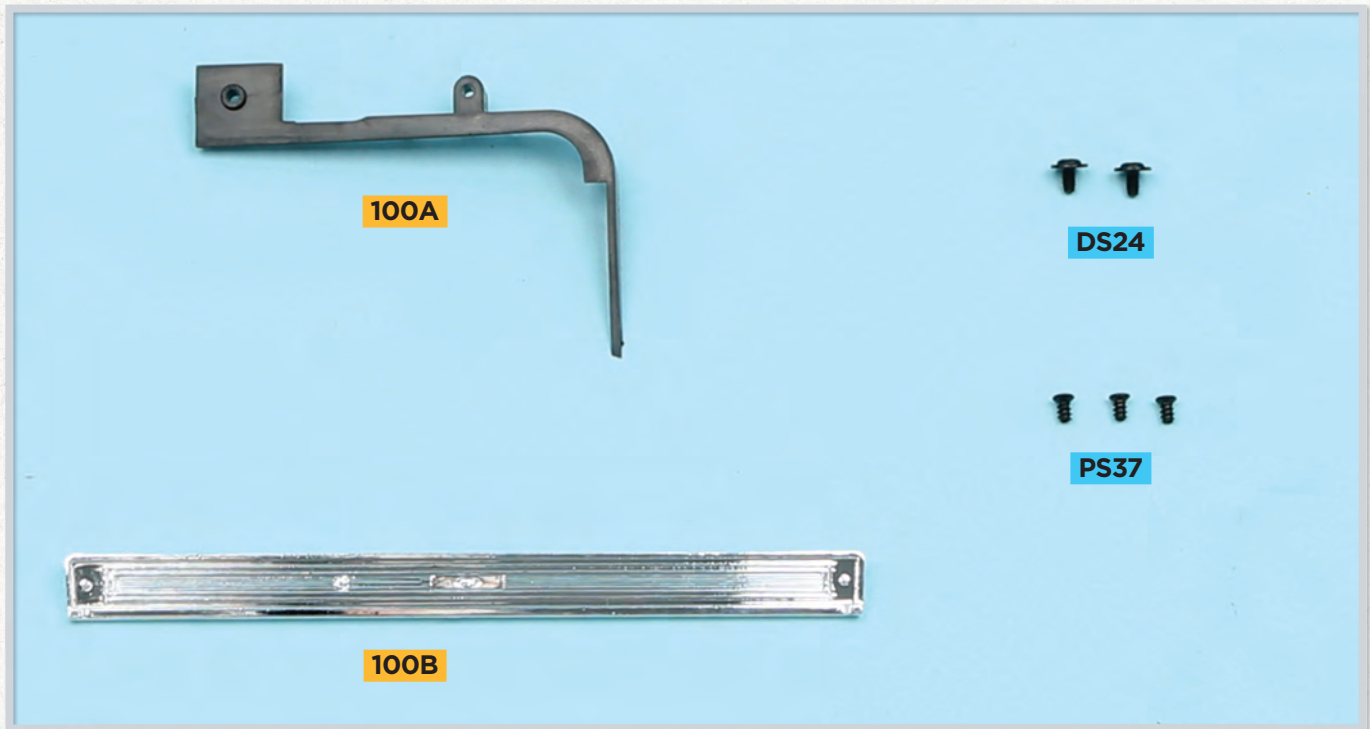

List of parts:

100A Inner part of left door frame

100B Left door threshold strip

DS24 Two* 2.3 x 4mm PWM screws

PS37 Three* 2.3 x 4mm KB screws

* Including spare

PWM = Flange head for metal

KB = Countersunk head for plastic

Area of assembly



Stage 100: Left Door

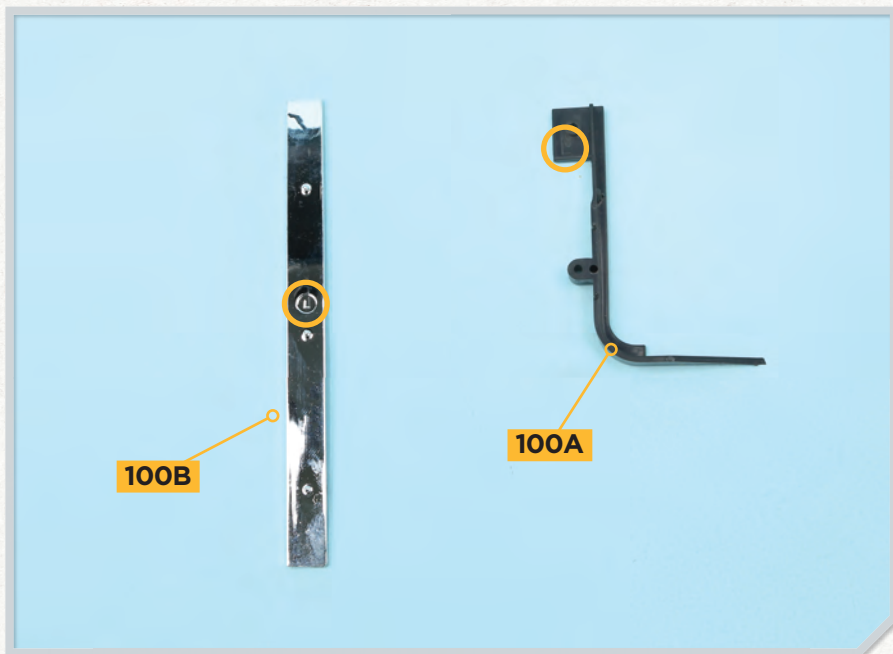

STEP 1

Note that the threshold strip **100B** and the door frame **100A** are marked L (circled).

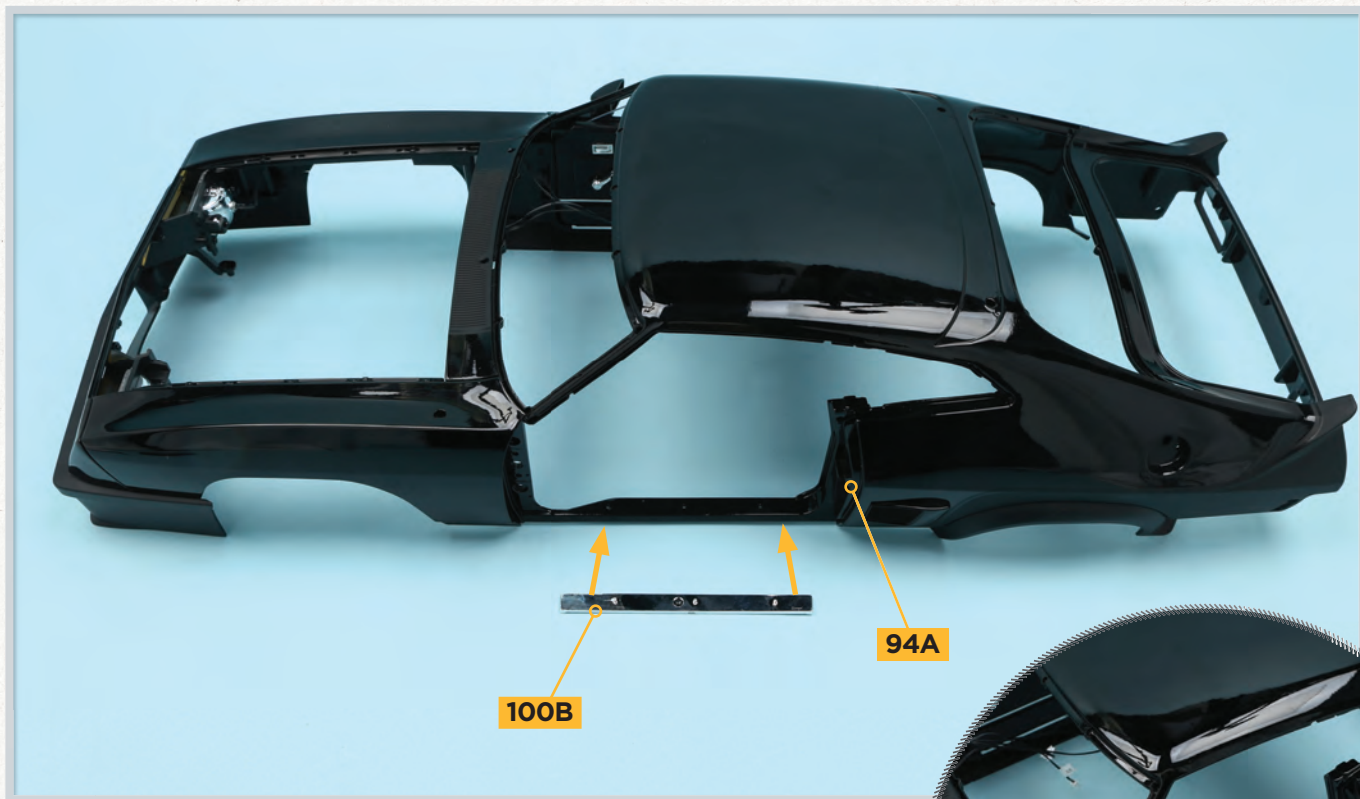

STEP 2

Take the car body assembly from the previous issue and position the threshold strip **100B** along the lower edge of the door opening. The L identified in the previous step faces downwards. Three pegs on part **100B** fit into holes in part **94A**. This is a push-fit connection.

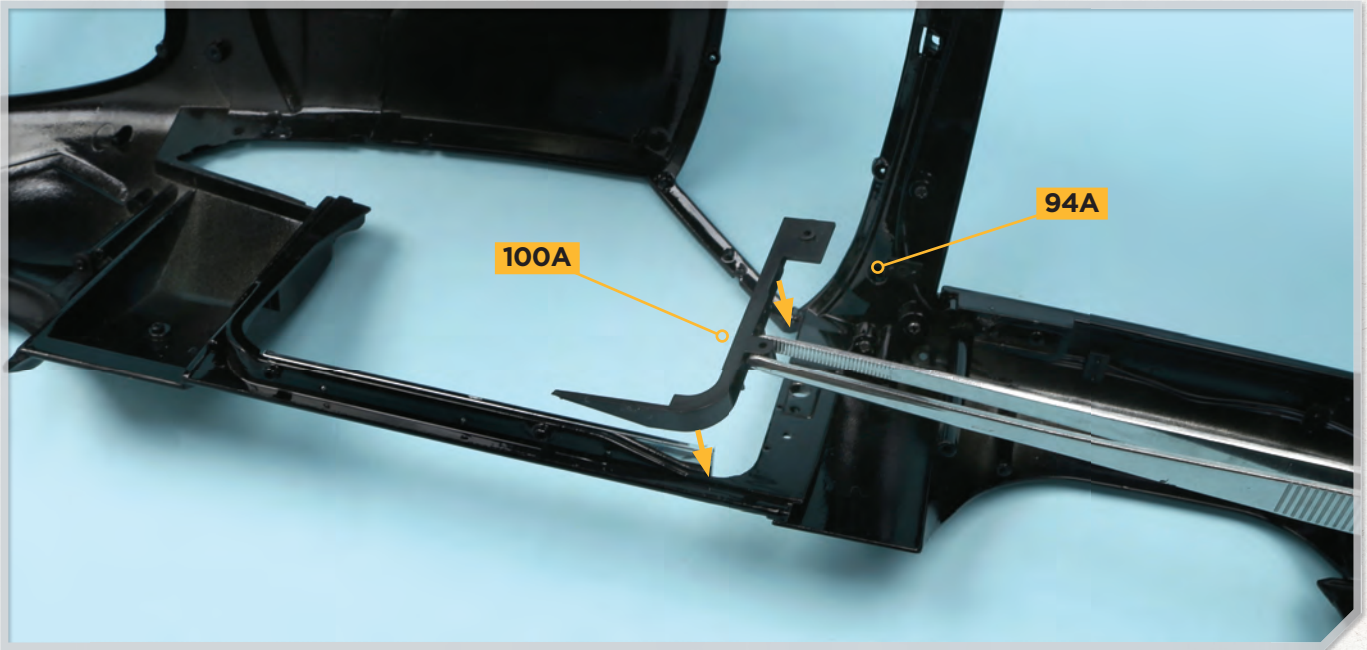

STEP 3

Turn the car body on its side and position the door frame **100A** inside the car body, down the front of the door opening. Two small pegs on part **100A** fit into holes near the door opening, and screw holes are aligned. The angled end of the frame matches the angled shape on the underside of the car body **94A**.

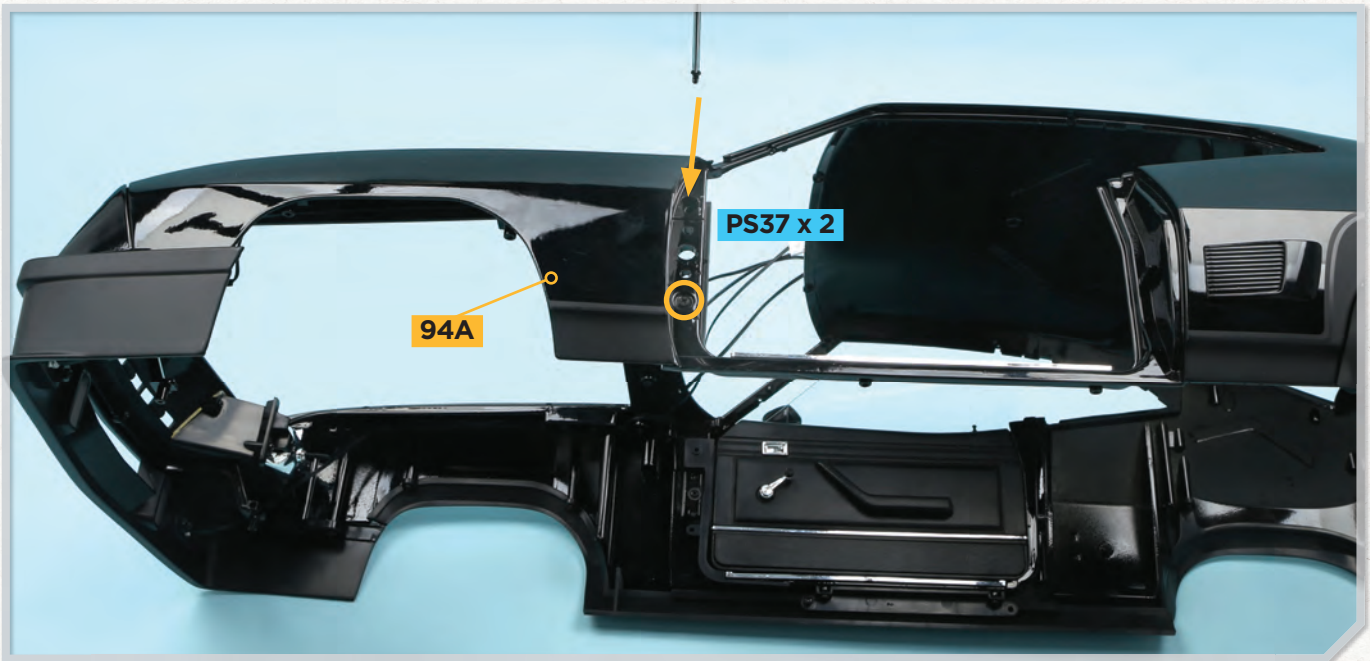

STEP 4

Fix the door frame **100A** to the car body **94A** with two **PS37** screws, inserted from the outside, through the car body and into the door frame.

Stage 100: Left Door

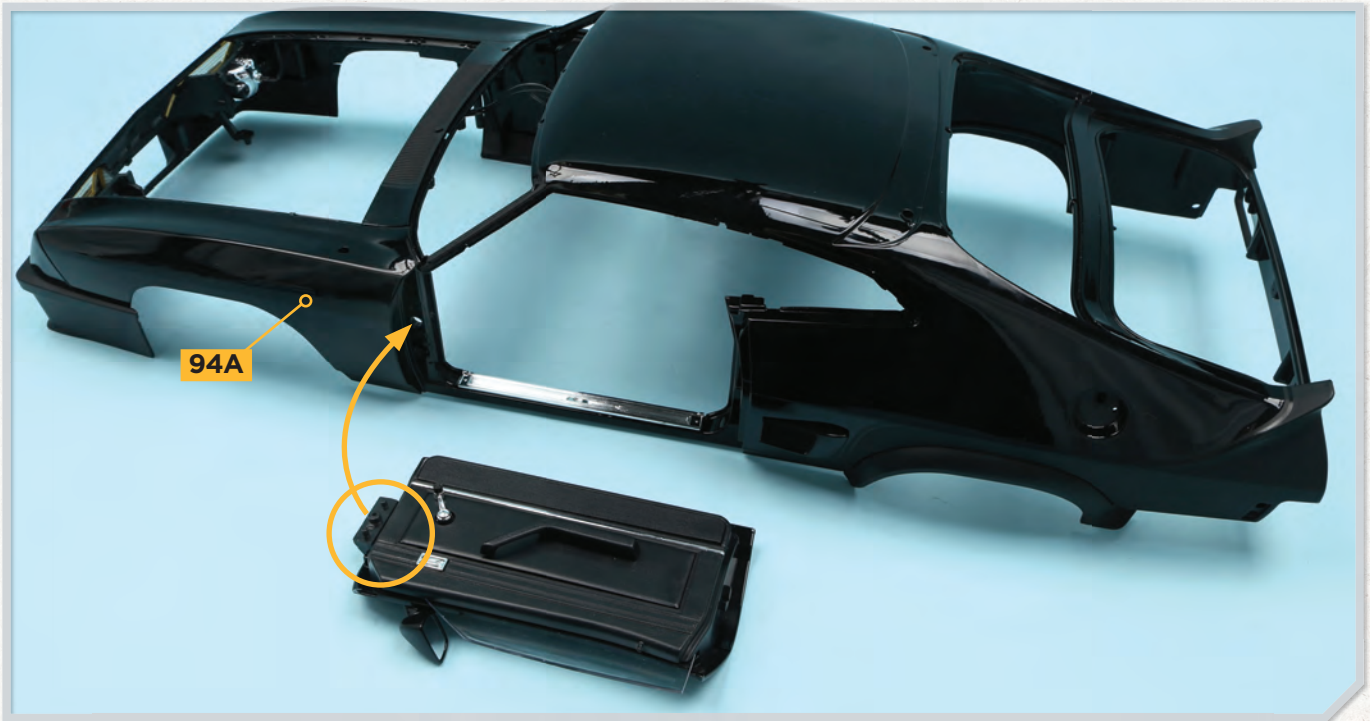

STEP 5

Take the left door assembly from issue 19. Identify the three holes in part **94A** at the front of the door opening, and the corresponding pegs and raised screw sockets on the door hinge **17F** (circled).



STEP 6

Fit the hinge part **17F** into the holes in the car body frame **94A**.



STEP 7

Position the assembly so that you can access the hinge. Fix the door in place with a **DS24** screw. Check that the door opens and closes freely.

COMPLETED ASSEMBLY

The left door has been attached to the car body.



COMING IN ISSUE 101



• ASSEMBLY GUIDE

The left front wheel arch and left sill trim are fitted to the model chassis.

• CARS ON SCREEN

The hugely successful science fiction movie *Back to the Future* (1985) was the highest grossing film of that year and, as automotive journalist Mike Renaut explains, unwittingly made a star of a fairly obscure sports car.

NEW PARTS

Mount for the sill trim, left wheel arch and sill trim and screws.



Published weekly

UK: £10.99

AUS: \$21.99



hachettepartworks.com/FordFalcon